

ANTI-VIBRATION MOUNTS FOR HARSH INDUSTRIAL ENVIRONMENTS

capacities 5kg - 300kg

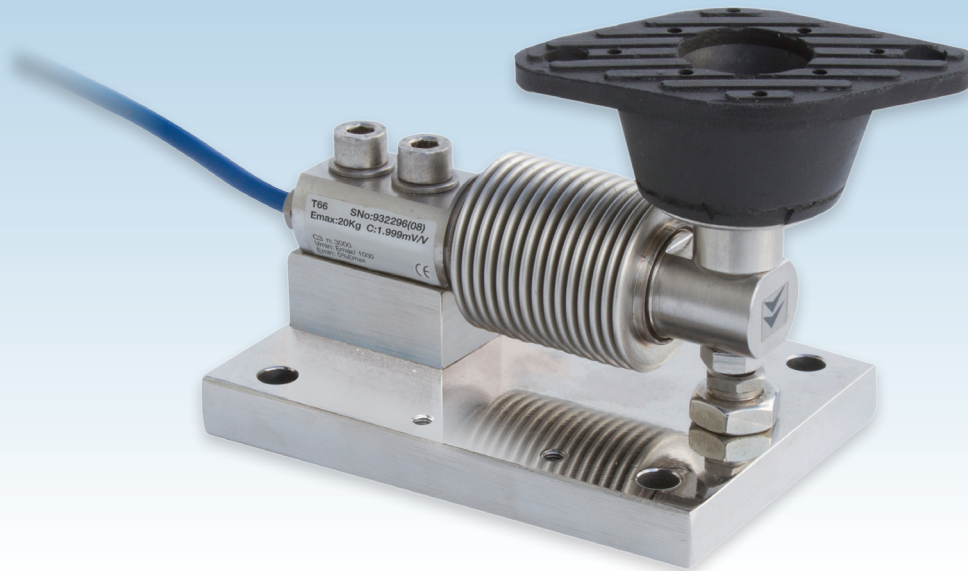

Ideal for applications with mixing, agitation and vibration, this stainless steel assembly is designed to reduce the vibration transmitted to the load cell. It is typically used in weighing platforms, big bag (FIBC) filling systems, belt weighers and hopper/tank weighing in the Food Processing, Chemical, Pharmaceutical and Bulk Handling industries.

The stainless steel, OIML C3 or C6 approved, model T66 load cell used in this anti-vibration weighing assembly is fully welded and hermetically sealed for protection to IP68 and IP69K, allowing it to be used in extremely harsh environments with exceptional accuracy. The assembly consists of a load cell, mounting hardware, baseplate and spacer (all stainless steel) with an elastomeric anti-vibration pad.

ATEX certification, for both gas and dust zones, is available for the T66 load cell. To reduce costs, certification for use in dust zones 20, 21 and 22 without safety barriers is available.

For applications in aggressive environments where stress corrosion or acid attack is an issue, a special Parylene coating for the load cell can be specified as an option. Other options are custom load cell cable lengths for volume OEM customers and a version for high temperature use.

- Stainless steel load sensor & mounting accessory
- Hermetically sealed, fully welded construction
- Simple, fast installation
- Sealed to IP68 / IP69K
- 3000 divisions OIML R60 Class C (C3)
- 5 year warranty
- High Integrity cable entry
- 6 wire (with sense wires) option
- High durability Polyurethane load cell cable
- Options of  approval, OIML C6 approval, Parylene coating or High Temperature use

LA66

technical specification...

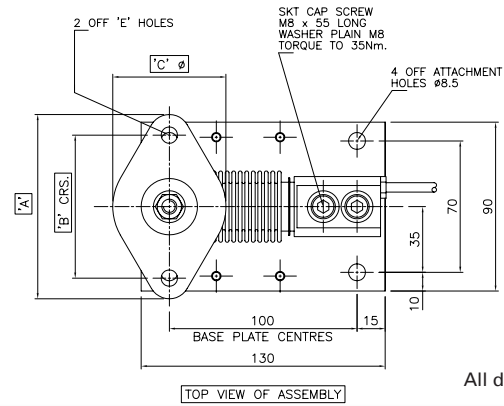
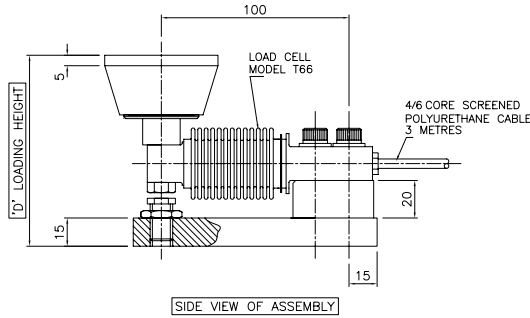

All dimensions in mm

T66 Load Cell ATEX Certification

Code	Temperature Class	Parameters	Application
II 1 GD Ex ia II CT4..T6 Ga IP68 T85°C Ex ia IIIC T135°C T85°C Da Ex ta IIIC T85°C Da	T4	Pi = 2.50W	Gas Zones 0, 1, 2 with safety barriers Dust Zones 20, 21, 22 without safety barriers
	T5	Pi = 2.50W	
	T6	Pi = 1.69W	

Dimensions

Capacity (kg)	A (mm)	B (mm)	C (mm)	D (mm)
5 - 50	79.4	60.3	44.5	95
75 - 300	98.4	76.2	60	103

T66 Load Cell

Accuracy Class	Load cell specification		Units
	3000*	6000	n. OIML
Load Cell Capacity (E _{max})	5, 10, 20, 30, 50, 75, 100, 150, 200, 250, 300	50, 75, 100, 150, 200, 250	kg
Rated Output (S _n)	2		mV/V ± 0.1 %**
Combined Error	< ± 0.017	< ± 0.008	% S _n
Non-repeatability	< ± 0.015	< ± 0.01	% S _n
Minimum load cell verification interval (v _{min}) = E _{max} / Y	E _{max} / 10000	E _{max} / 18000	kg
Creep (30 minutes)	< ± 0.016	< ± 0.008	% S _n
Temperature Effect on Zero Balance	< ± 0.002	< ± 0.001	% S _n / °C
Temperature Effect on Span	< ± 0.0012	< ± 0.0006	% S _n / °C
Compensated Temperature Range	-10 to +40		°C
Operating Temperature Range	-30 to +70		°C
Safe Overload	200		% E _{max}
Ultimate Overload	300		% E _{max}
Zero Balance	< ± 2		% S _n
Input Resistance	400		Ω ± 20
Output Resistance	350		Ω ± 3
Insulation Resistance	> 5000		MΩ @ 100V
Recommended Supply Voltage	5-15		V
Maximum Supply Voltage	15		V
Environmental Protection	IP68 / IP69K		-
Maximum deflection at E _{max}	0.2-0.4		mm
Cable Length	3		m
Cable Material	Polyurethane		-
Nominal Shipping Weight (load cell and LA66)	4.5		kg

* OIML C3 (3000 division) approval from 10-300kg
** For 5-20kg capacity range, rated output (S_n) tolerance is ± 0.2 %

4 Wire Connection (C3 only)

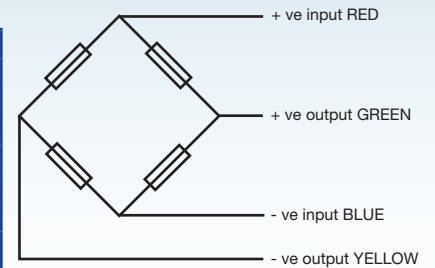

6 Wire Connection (C3 or C6)

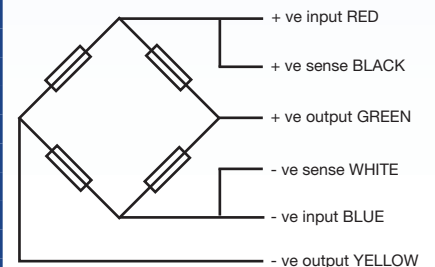

Electrical Connections

Via 4 or 6 wire, 5.7mm diameter, screened Polyurethane cable. OIML C6 version only available with 6 wire cable.
Screen not connected electrically to load cell.

Construction

T66 load cell: stainless steel
Baseplate and mounting hardware: stainless steel

DISTRIBUTED BY:



THAMES SIDE SENSORS LTD

Unit 10, io Trade Centre, Deacon Way, Reading, Berkshire RG30 6AZ

tel: +44 (0) 118 941 1387
fax: +44 (0) 118 941 2004

sales@thames-side.co.uk
www.thames-side.com



Issue: LA66.12.16

Our policy is one of continuous product enhancement. We therefore reserve the right to incorporate technical modifications without prior notification.

