

# LOW PROFILE WEIGHING ASSEMBLY FOR SILO, TANK AND VESSEL WEIGHING

*capacities 1t to 30t*

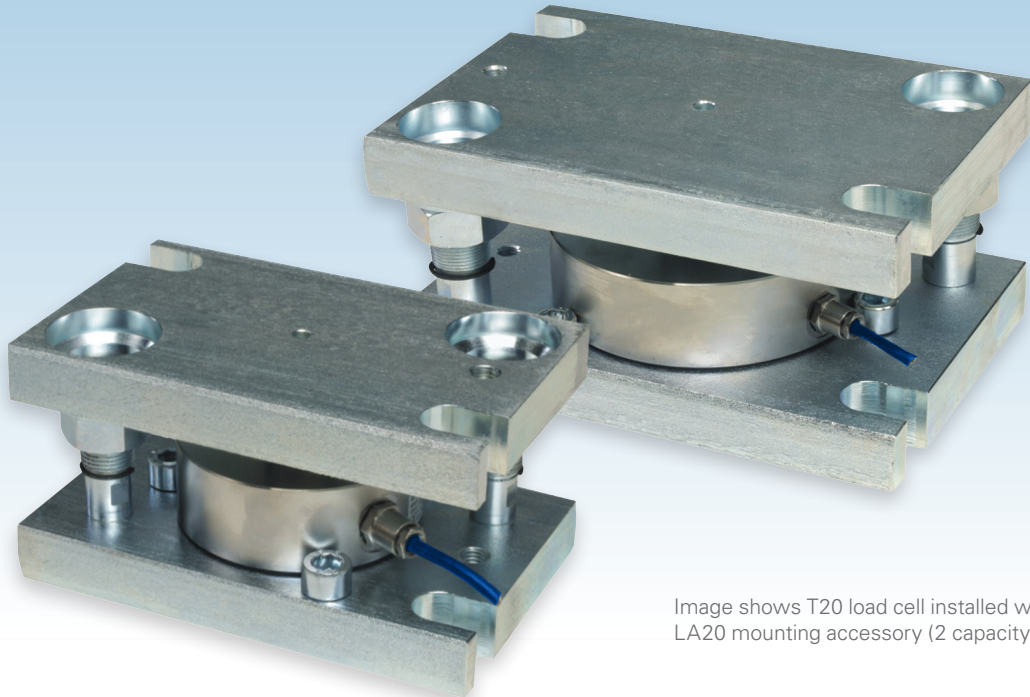

Image shows T20 load cell installed within LA20 mounting accessory (2 capacity ranges)

The T20 Weighing Assembly is specifically designed as a reliable, simple, low cost solution for weighing of tanks, silos and vessels where 'level measurement' is the main requirement. It offers an excellent compromise between accuracy and cost.

The stainless steel T20 load cell is mounted in either a zinc plated or stainless steel, compact LA20 mounting accessory that has integral jacking bolts to allow for load cell installation and removal, lift-off prevention and allowance for the angular misalignment that is often present in silos or other metal structures. The LA20 accessory incorporates a hardened alloy steel or stainless steel load bearing surface, for optimum force application to the T20 load cell.

The design is suitable for use either as a totally live system with load cells under all legs/support points of the vessel or – where cost is critical – as a dummy system with either one live and two dummy cells (total 3 cells) or two live and two dummy cells (total 4 cells).

- Stainless steel compression load cell
- Fully welded and hermetically sealed construction to IP68/IP69K
- Allows for thermal expansion and contraction of vessel
- Integral jacking facility to lift accessory
- 1000 division accuracy
-  option
- Low profile, extremely compact mounting accessory
- Integral lift-off prevention
- Allowance for angular mis-alignment
- 5 year warranty
- Durable polyurethane cable with high resistance to chemicals, impacts and UV radiation
- Optional Parylene coating for aggressive environments



# T20

technical specification...

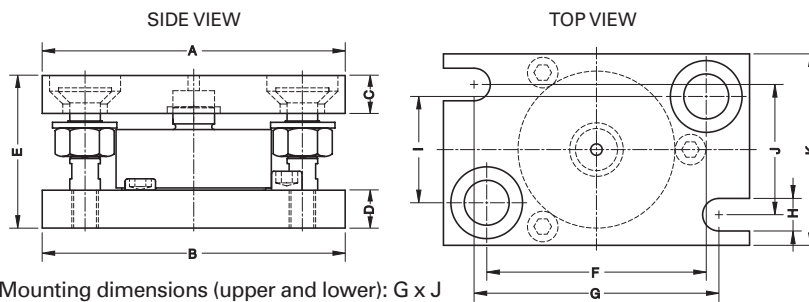

Mounting dimensions (upper and lower): G x J

## Mounting Proposals

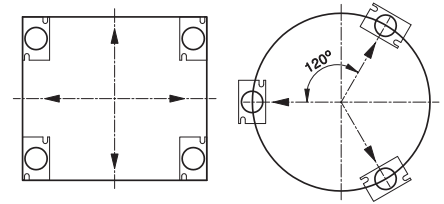

## T20 Load Cell

	Load cell specification	Units
<b>Load Cell Capacity (<math>E_{max}</math>)</b>	1, 2.5, 5, 10, 20, 30	tonnes (t)
<b>Rated Output (<math>S_n</math>)</b>	2.0	mV/V $\pm$ 0.1%
<b>Combined Error</b>	$< \pm 0.05$	% $S_n$
<b>Non-repeatability</b>	$< \pm 0.015$	% $S_n$
<b>Minimum load cell verification interval (<math>V_{min}) = E_{max} / Y</math></b>	$E_{max} / 10000$	kg
<b>Creep (30 minutes)</b>	$< \pm 0.048$	% $S_n$
<b>Temperature Effect on Zero Balance</b>	$< \pm 0.002$	% $S_n / ^\circ C$
<b>Temperature Effect on Span</b>	$< \pm 0.0036$	% $S_n / ^\circ C$
<b>Compensated Temperature Range</b>	-10 to +40	$^\circ C$
<b>Operating Temperature Range</b>	-50 to +70	$^\circ C$
<b>Safe Load Limit (<math>E_{lim}</math>)</b>	200	% $S_n$
<b>Zero Balance</b>	$\pm 2.0$	% $S_n$
<b>Insulation Resistance</b>	$> 5000$	M $\Omega$
<b>Environmental Protection according to EN 60529</b>	IP68 / IP69K	
<b>Cable Length</b>	3	m
<b>Maximum deflection at <math>E_{max}</math></b>	$< 0.6$	mm
<b>Nominal Shipping Weight (Load Cell with Accessory)</b>	1t -10t	7.0 kg
	20t -30t	15.8 kg

## Dimensions

Capacity (t)	1, 2.5, 5, 10	20, 30
A, B	160	218
C, D	20	25
E	80	100
F	115	168
G	128	180
H	17	21
I	55.5	100
J	68	100
K	100	150

All dimensions in mm

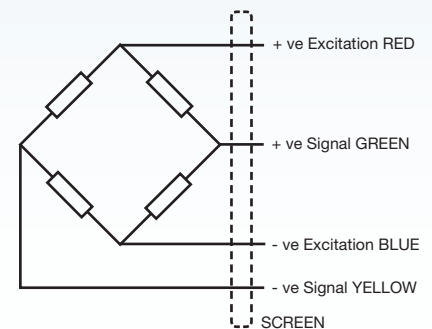

## Electrical Connections

Via 4 core, 5.7mm diameter, screened polyurethane cable.  
Screen not connected electrically to load cell.

## Construction

Load cell T20  
Stainless steel

Mounting accessory LA20

- Zinc plated version LA20-\*\*\*-ZINC  
Upper plate, lower plate, hardware: zinc plated alloy steel
- Stainless steel version LA20-\*\*\*-SS  
Upper plate, lower plate, hardware: stainless steel

## LA20 Weighing Assembly Data

Mounting Accessory	Load Cell Capacity (t)	Maximum Lift Off Load (kg)	Maximum Side or End Load (kg)	Maximum Side Offset (mm)
LA20-10T-ZINC LA20-10T-SS	1, 2.5, 5, 10	7339	2243	$\pm 3$
LA20-30T-ZINC LA20-30T-SS	20, 30	12644	3262	$\pm 3$

The above data is applicable with or without the load cell installed.

## T20 Load Cell ATEX Certification

Code	Temperature Class	Parameters	Application
II 1 GD Ex ia IICT4...T6 Ga IP68T85°C Ex ia IICT85°C Da Ex ta IICT85°C Da	T4	$P_i = 1.3W$	Gas Zones 0, 1, 2 with safety barriers Dust Zones 20, 21, 22 <b>without</b> safety barriers
	T5	$P_i = 0.5W$	
	T6	$P_i = 0.2W$	

DISTRIBUTED BY:



## THAMES SIDE SENSORS LTD

Unit 10, io Trade Centre, Deacon Way,  
Reading, Berkshire RG30 6AZ, UK

tel: +44 (0) 118 941 1387  
fax: +44 (0) 118 941 2004

sales@thames-side.co.uk  
www.thames-side.com



Issue: T20.10.17

Our policy is one of continuous product enhancement. We therefore reserve the right to incorporate technical modifications without prior notification.

